

# Electric Modu-Flo II Pump

## DESCRIPTION

The electric Modu-Flo II pump is a rugged electric motor driven positive displacement piston pump. It is designed for use with Trabon series progressive divider valves to lubricate all types of machinery using oil or grease up through NLGI #2. The electric Modu-Flo II pump is modular in design and utilizes Modu-Flo reservoirs, components and accessories. The assembly comes complete with electric motor and 20 ft. cable. The 24 VDC version is capable of delivering .29 cu.in./min. (4.7 cc/min.) at pressures up to 2500 psi (170 bar). The 115 VAC version is rated at .58 cu.in./min (9.5 cc/min.) at pressures up to 2500 PSI (170 bar).

## FEATURE/BENEFITS

- Used with Trabon series progressive divider valves. The electric Modu-Flo II pump provides automatic centralized lubrication extending the life of machine components and increasing machine productivity.
- The electric motor driven pump is designed for use where air or hydraulics is not available and/or desired.
- Minimizes system cost by reducing hardware and lowers operating costs.
- Enclosed in a rugged metal housing, the 24 VDC Modu-Flo pump is suitable for outdoor applications, and can be used with mobile equipment. The 115 VAC version is suitable for indoor use only.
- Recommended for use with either oil or grease systems up through NLGI #2 dependent upon ambient temperatures. Allows for wide selection of lubricants.
- Designed to allow use with Modu-Flo modular reservoirs, components and accessories. Standard components help reduce inventory.
- 24 VDC version available with built in optional timer.



## GENERAL INSTRUCTIONS

The Electric Modu-Flo Pump is mounted to a Modu-Flo pump manifold and wired to the customer's controls per the wiring information. The control output voltage must be greater than 2.0 amps.

The lubricant being used must be pumpable at ambient operating temperature to ensure proper operation of pump. Consult factory for guidelines.

- See bulletin L12000 for additional information on Modu-Flo reservoirs and accessories.

## OPERATION

The Electric Modu-Flo II Pump is operated by an electric motor (1) connected to an eccentric (2) thru a reducer gear (3), driving the linkage (4) and piston (5). As the piston moves forward in the power stroke, the inlet (6) is closed off and the lubricant unseats the outlet check valve (7) and delivers the lubricant to the system. As the eccentric continues to rotate, the piston moves back reopening the inlet and returning the piston to full prime position, ready for the next delivery stroke.

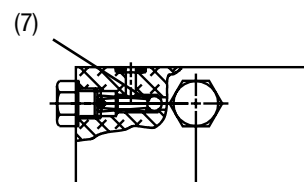
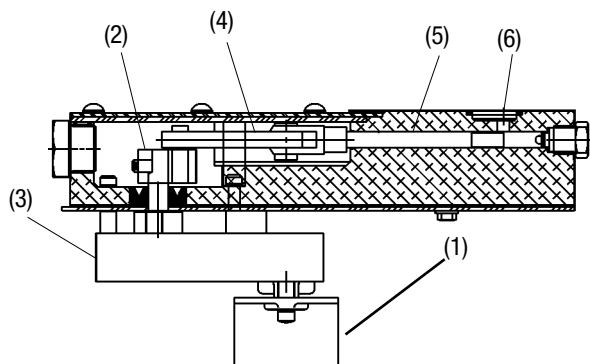

## SPECIFICATIONS

SPECIFICATION	
<b>Standard Pump</b>	
<b>Outlet per stroke</b>	0.024 cu.in. (0.4 cc)
<b>Cycle Rate</b>	24 VDC - 12 RPM 115 VAC - 24 RPM
<b>Max Output per Min</b>	24 VDC - 0.29 cu.in. (4.7 cc) 115 VAC - .58 cu.in. (9.5 cc)
<b>Max Operating Pressure</b>	2500 psi (172 bar)
<b>Lubricants</b>	Oil and Grease (up thru NLGI #2)
<b>*Motor Voltages</b>	24 VDC, 115 VAC
<b>Current Draw</b>	24 VDC - 2A 115 VAC - 1.6A @ max. operating pressure
<b>Electrical Connection</b>	Hirschmann
<b>Duty Cycle:</b>	
0-1499 psi (0-103 bar)	50%
1500-2500 psi (104-172 bar)	25%
<b>Max Run Time</b>	4 minutes
<b>Operating Temperature</b>	20°F to 140°F (-7°C to 60°C) (Assumes pumpability of lubricant) (Consult factory for lower temperatures)
<b>Operating Environment</b>	24 VDC - Inside/Outside 115 VAC - Inside Only
<b>Timer (Option)</b>	24 VDC (only)
<b>On-Time</b>	1-100 Sec
<b>Off-Time</b>	.02-2 Hrs (1.2-120 Min)

\* 24 VDC pump without timer can be operated on 12 VDC. Pump output will be reduced to .14 cu.in. per min. and current draw will increase to 4A at max. operating pressure.

## DIMENSIONS Inches (mm)

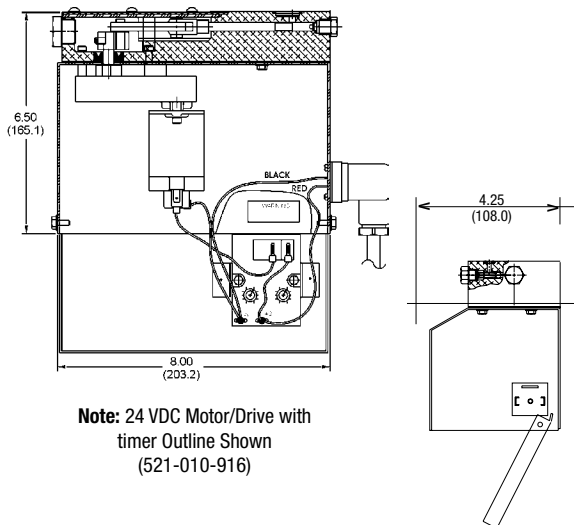

## WIRING

### Motor Hook Up (24 VDC)

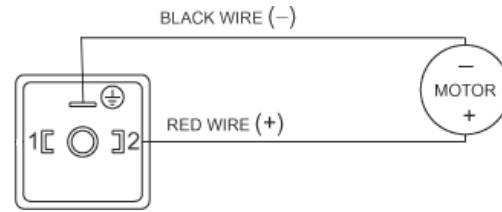

Customer wiring from harness

Red wire (+)	Customer hook up
Black wire (-)	Customer hook up
Orange	Not Used
Blue	Not Used

### Motor Hook Up (115 VAC)

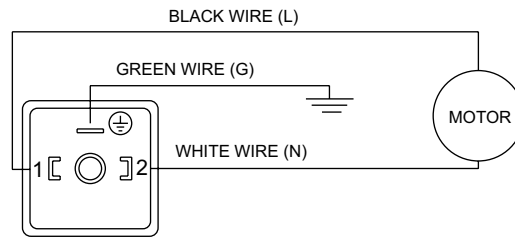

Customer wiring from harness

Black wire (Live)	Customer hook up
White wire (Neutral)	Customer hook up
Green wire (Gn'd)	Customer hook up

## HOW TO ORDER

Description	Part No.	Old Part No.
24 VDC motor w/20 ft conn. cable	563356	521-010-915
24 VDC motor w/20 ft conn. cable & timer	Dis.	521-010-916
24 VDC motor w/20 ft conn. cable, 12 lb reservoir, & low level switch	-	120-505-330
115 VAC motor w/20 ft conn. cable	563346	521-007-060
115 VAC motor w/out 20 ft conn. cable	564371	521-007-040

## SPARE PARTS

Description	Part No.	Old Part No.
20 ft conn. cable (24 VDC)	-	492-240-152
20 ft conn. cable (115 VAC)	-	492-240-196
Pump Repair Kit	Dis.	560-500-221
24 VDC Gearmotor	557287	493-040-069
115 VAC Gearmotor	-	493-040-054

Graco endorses the SAE recommendation of ISO 18/14 (ISO 4406) oil cleanliness for most bearing applications. Some high speed bearings may require cleaner oil. Consult the bearing manufacturer for recommendation.

All written and visual data contained in this document are based on the latest product information available at the time of publication. Graco reserves the right to make changes at any time without notice.

## Contact us today!

To receive product information or talk with a Graco representative, call 800-533-9655 or visit us online at [www.graco.com](http://www.graco.com).

